



## Spiromatic & Revitox breathing valve

This safety advice applies to breathing valves with serial number 1631001 to 2107999 and spare part kits containing valve inserts with manufacturing date 01.08.2016 to 09.02.2021. Older breathing valves may also be affected by this bulletin if they have undergone service and had valve inserts fitted that were manufactured during this period.

There could be exceptional circumstances where the air delivery through the unit could be restricted or even potentially ceased due to mechanical damage on the lever support. Such damage can occur if the lever height is adjusted incorrectly or if the lever on a removed valve insert is handled in such a manner that it is angled over by more than 50 degrees. Damage can also occur during normal use by wear.

By replacing the lever with a new version the risk of this failure mode is eliminated. The lever support with sealing diaphragm must be replaced at the same time. The replacement procedure is required to be performed by a certified service technician according to the instructions detailed within this bulletin.

**The following visual inspection procedure shall be performed as soon as possible.**

- If damage is detected, or if the lever height is too low, the replacement must be carried out **before using the breathing valve again.**
- If no damage is detected and the lever height is within the approved range, the parts must be replaced **at the next annual service.**

To order a free replacement kit or to update your spare part kits, contact:

UK customers: [infouk@interspiro.com](mailto:infouk@interspiro.com)

NL customers: [infobv@interspiro.com](mailto:infobv@interspiro.com)

US customers: [tim.hammes@interspiro.com](mailto:tim.hammes@interspiro.com)

Other customers: [order.sverige@interspiro.com](mailto:order.sverige@interspiro.com).

State the serial number marked on the breathing valves, the replacement kit's article number 57542-52 and the quantity. If you have service kits that need to be updated, state the manufacturing date of the kits and quantity needed. Please initially confirm only the quantity failing the visual inspection. Further items required should be quantified and ordered separately in connection with the annual service.

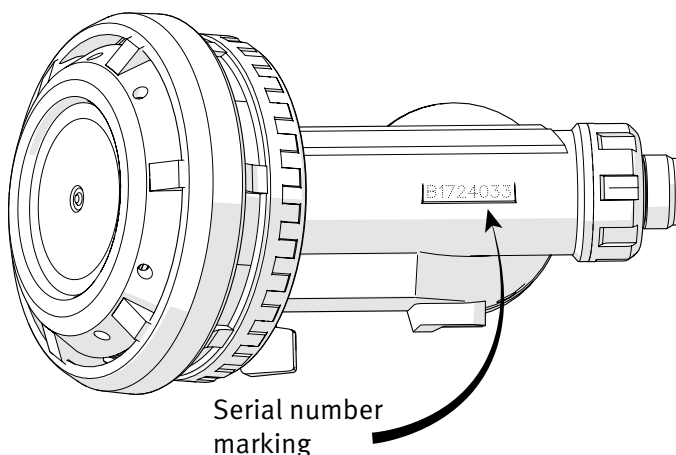



## Visual inspection

### 1. Remove the exhalation unit.

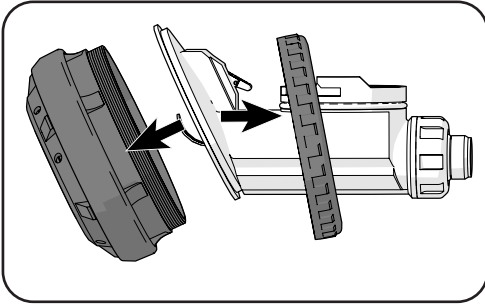

**2. Check if the lever has a punched dot on it.** If it has a dot, it is the new version and there are no need to check the lever height or inspect the surfaces of the lever support.



**3. Check the lever height.** If it is too low, replacement must be done before the next use, as this may be a sign of wear without visible damage.

*With lever bar:* The lever should be in the upper part of the cut-out.

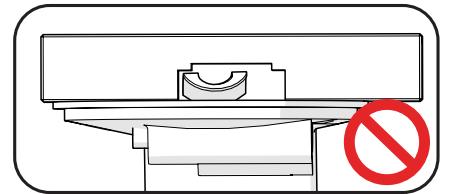
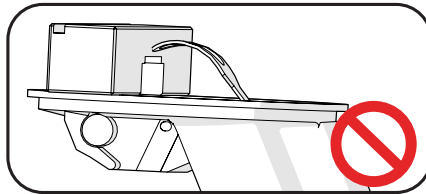
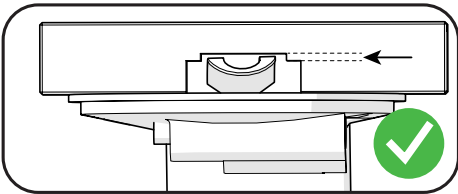

*Without lever bar:* Remove the exhalation unit except the locking ring. Push the locking ring upwards so that it lies against the edge.

Check that you can see a gap between the lever and the upper edge of the locking ring.

Important! Hold the breathing valve upwards as shown in the image.

**Important!** It is not permitted to manually bend the lever to make a gap.

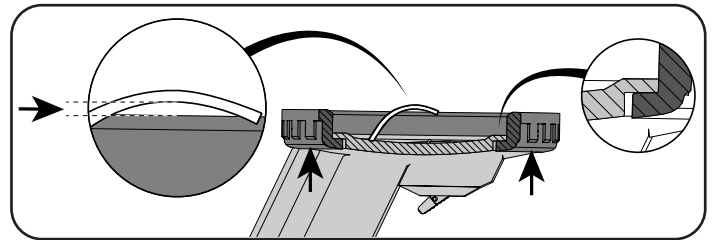

### 4. Check the contact surfaces on the lever support.

Check that the contact surfaces and the outside surface of the lever support is undamaged. If it is damaged like in the images, the parts must be replaced before the breathing valve is used again.

Note! The images shows damages on a Divator lever support.

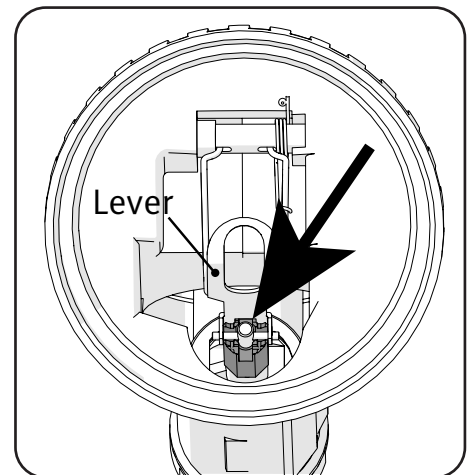
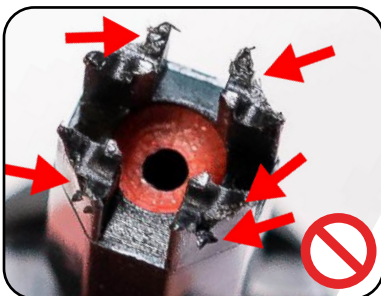



# Safety advice



**INTERSPIRO**

## Replacement of parts in the exchange kit



### WARNING

Service technicians who perform all service and all repairs on Interspiro's breathing equipment must be trained and certified to level 3 by Interspiro regarding the specific apparatus.



### WARNING

The manual "Module 1 Firefighting & Diving" must be read and the instructions in the document followed when any form of service, test or repair is performed on the apparatus. Failure to do so could result in serious equipment damage, personal injury or death.



### WARNING

Make sure that the apparatus is depressurized before starting any service or repair. A pressurized apparatus during service or repair may cause serious damage.

1. Remove the exhalation unit and the nut.
2. Pull out the valve insert.

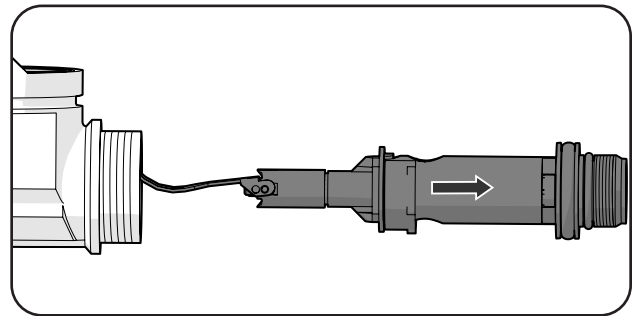
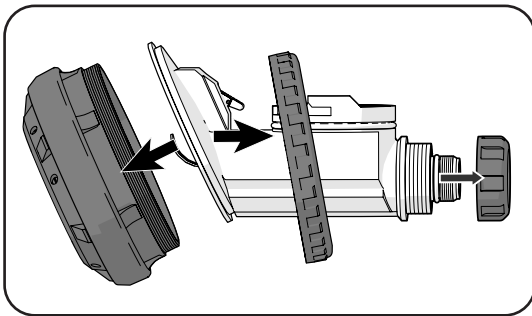

3. Remove the retaining ring and then pull out the valve insert from the connection nipple.

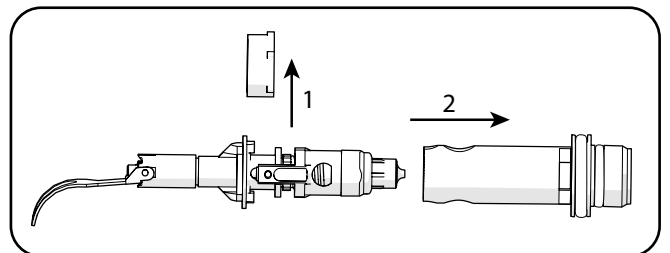

4. Press together the valve insert by hand so that the pin can fall out.

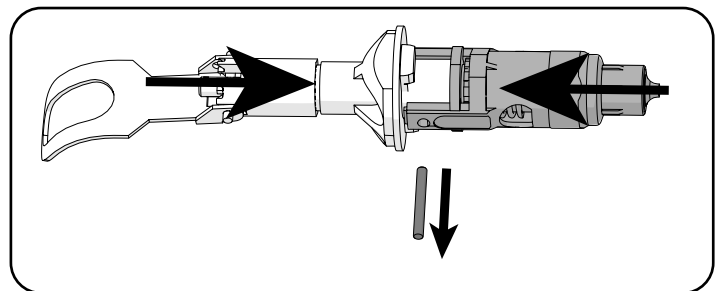

5. Disassemble the parts.

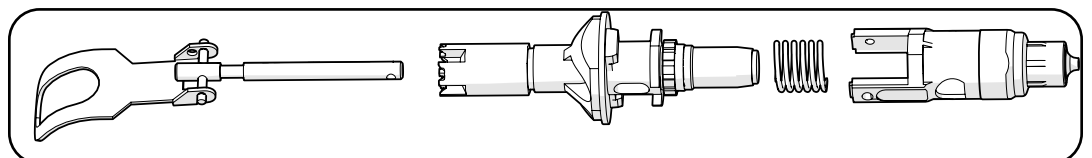



6. Remove the lever support and discard the lever and the lever support.

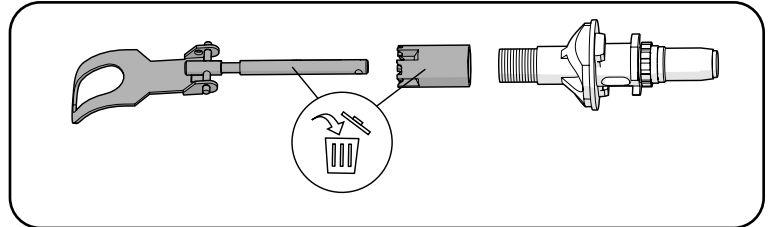

7. Check that the sealing membrane (A) is located in the lever support.

8. Carefully tighten the lever support by hand. Then turn it counter-clockwise a few turns to get about 0.7 mm spacing.

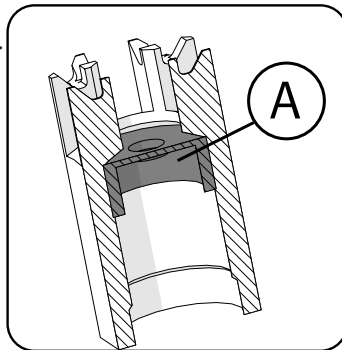

9. Adjust the adjusting nut to get about 1.5 mm spacing.

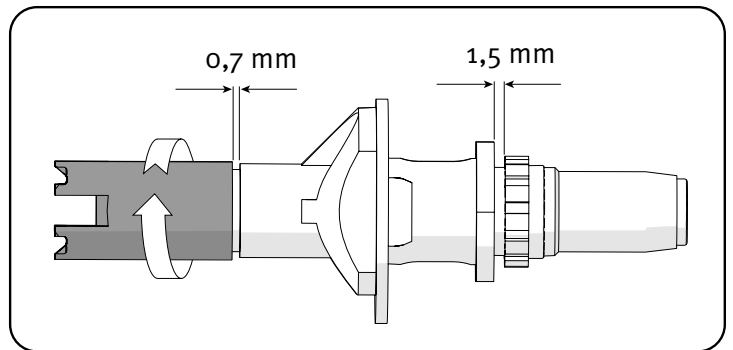

10. Mount the lever in the lever support with the pin in one of the deep slots. Check that the bend ends up in the right direction according to the rounded side of the valve insert.

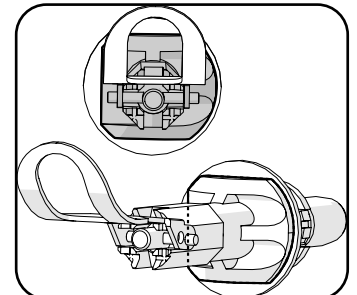
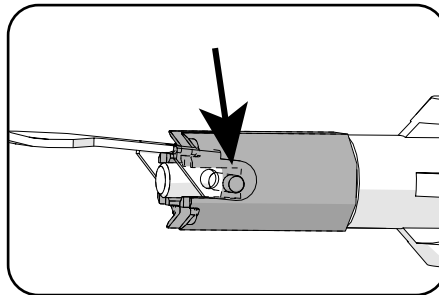

11. Assemble the valve insert with the new lever and lever support. Press the valve insert together and put the pin back.

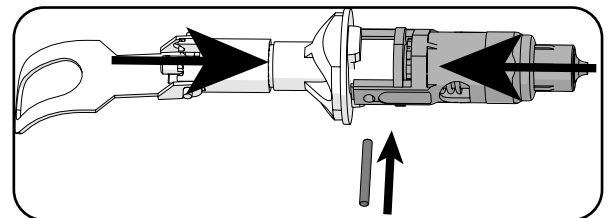

12. Assemble the valve insert sub assembly in the connection nipple and lock it with the retaining ring. Make sure to fit the retaining ring correctly.

The valve insert sub assembly and the connection nipple should not be able to be pulled apart.

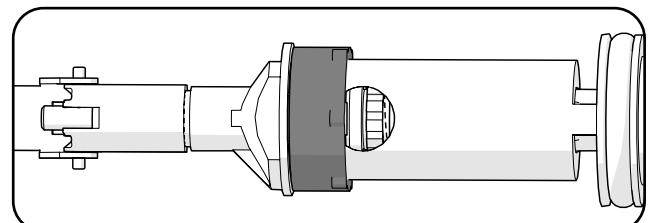
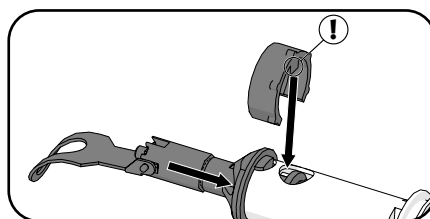



13. Insert the valve insert assembly in the breathing valve. Make sure to insert it in the correct position.

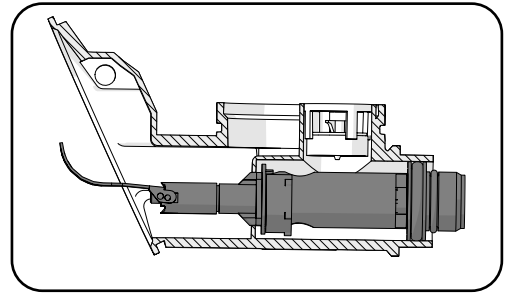
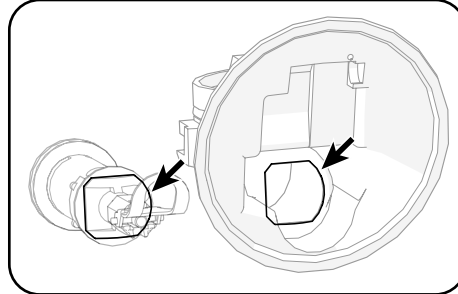

14. Assemble the nut by hand.  
15. If the breathing valve is of safety pressure type. Make sure that the handle is in the position shown in image.

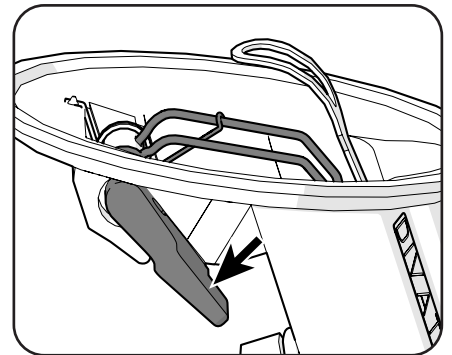
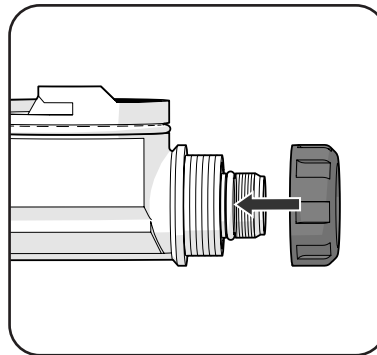

16. Make sure that the lever has a resistless movement of at least 3 mm.

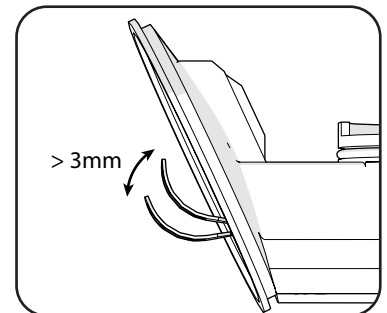

17. Use the lever bar to make sure that the lever is in the correct height. The lever must be in the upper area of the lever bar.

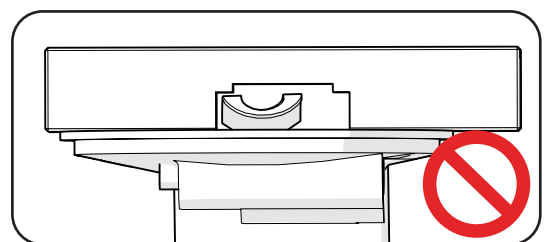
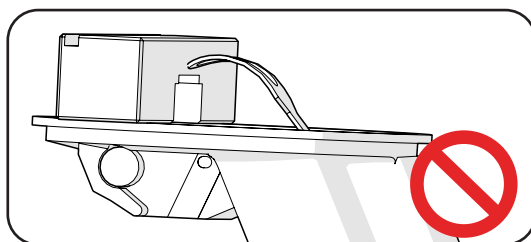
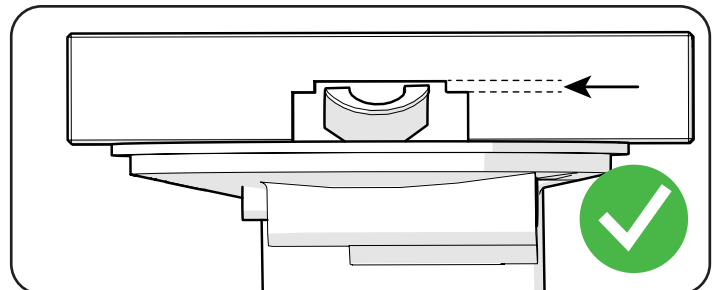



18. If height adjustment of the lever is necessary:
  - a, Disassemble the valve insert from the breathing valve.
  - b, Pull out the lever (A) and turn the lever support (B) 1 step to make it higher or lower.
  - c, One quarter turn results in a height difference of 1,25 mm on the lever.
  - d, Make sure to put the lever in one of the deeper grooves in the lever support as seen on image.
  - e, If two settings is possible within the limits, use the highest setting.
  - f, Reassemble the valve insert into the breathing valve and check the lever according to step 16 and 17 again.

**IMPORTANT!** When adjusting the height of the lever, it is very important that part A is lifted high enough so that part B does not touch part A when adjusting. When part A is released, it is very important that it slides directly into the correct position. If it is placed incorrectly, it can damage the lever support.

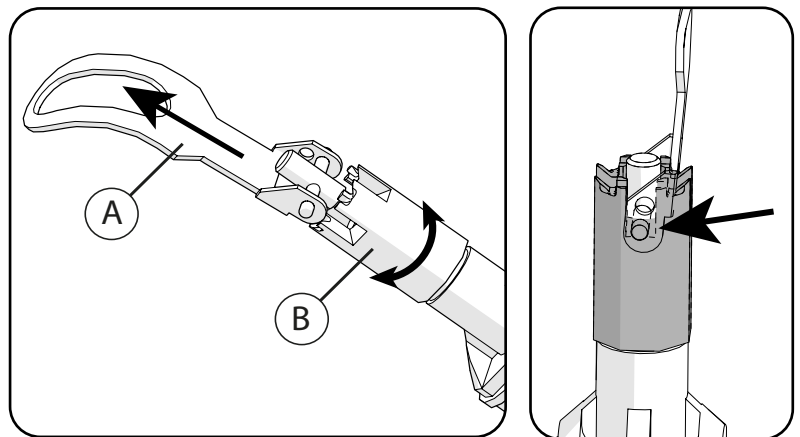

**IMPORTANT!** Never angle the lever more than 50 degrees as this may damage the contact surfaces on the lever support. When the valve insert is mounted in the breathing valve housing, the lever is prevented from angling more than 50 degrees. When the valve insert is removed from the breathing valve housing, the lever can be angled more than 50 degrees and thus damage the lever support.

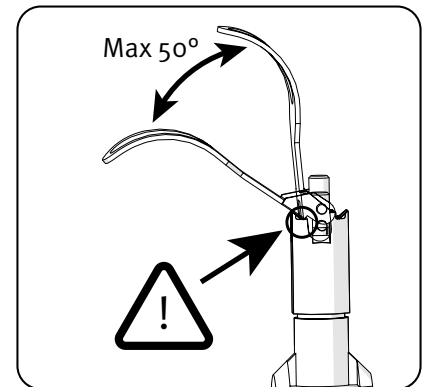

19. Reassemble the exhalation unit and the nut.

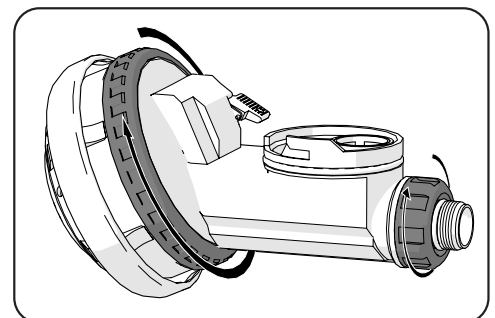
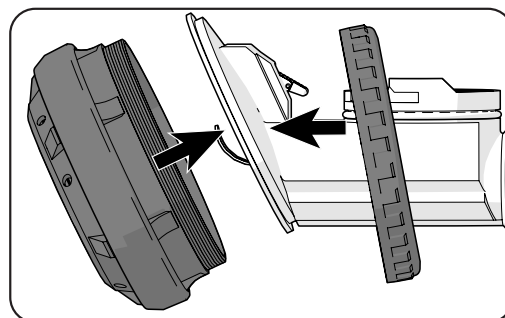

20. Do a performance test on calibrated test equipment recommended by Interspiro.